

II - Cellules de l'immunité adaptative

Lymphocytes B

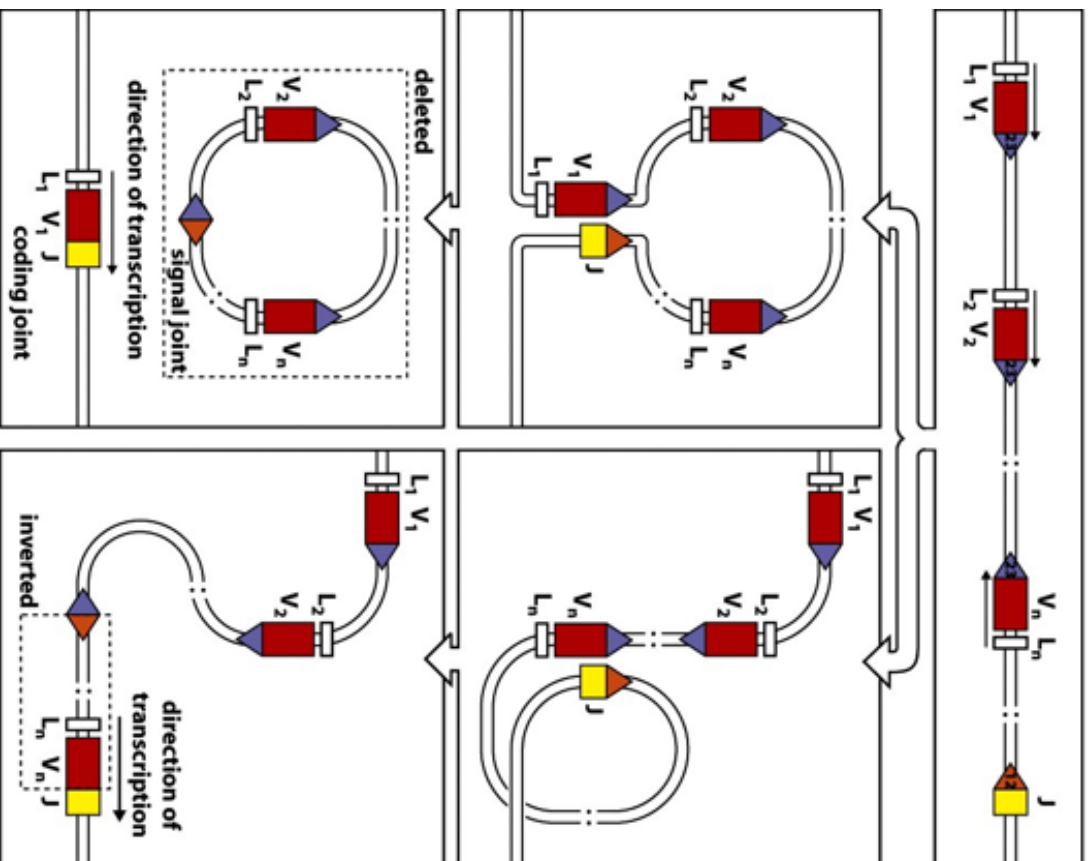

II - Cellules de l'immunité adaptative

Lymphocytes B

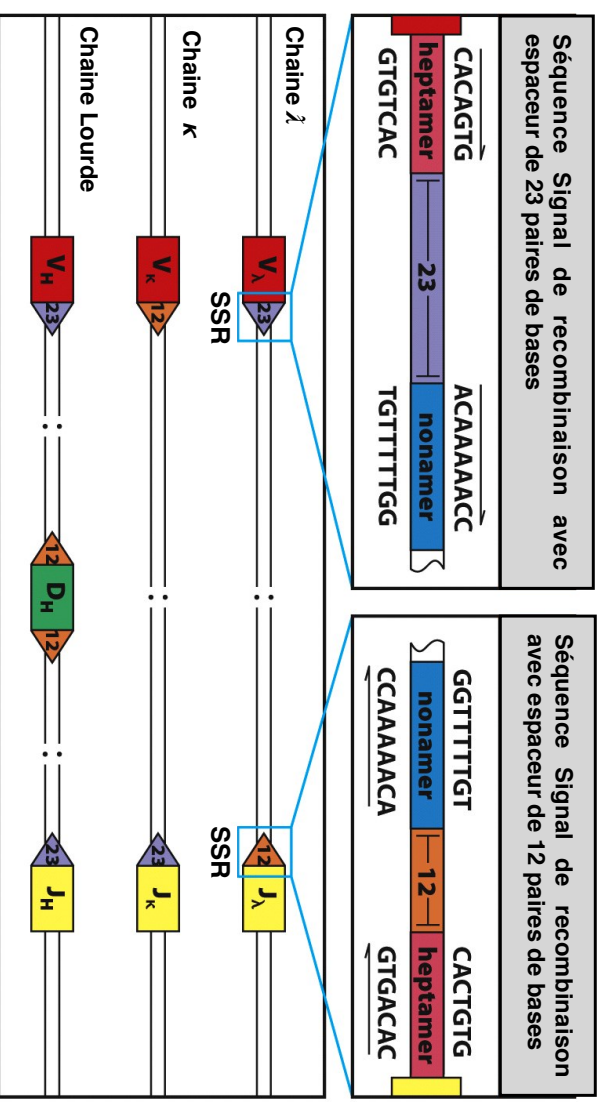
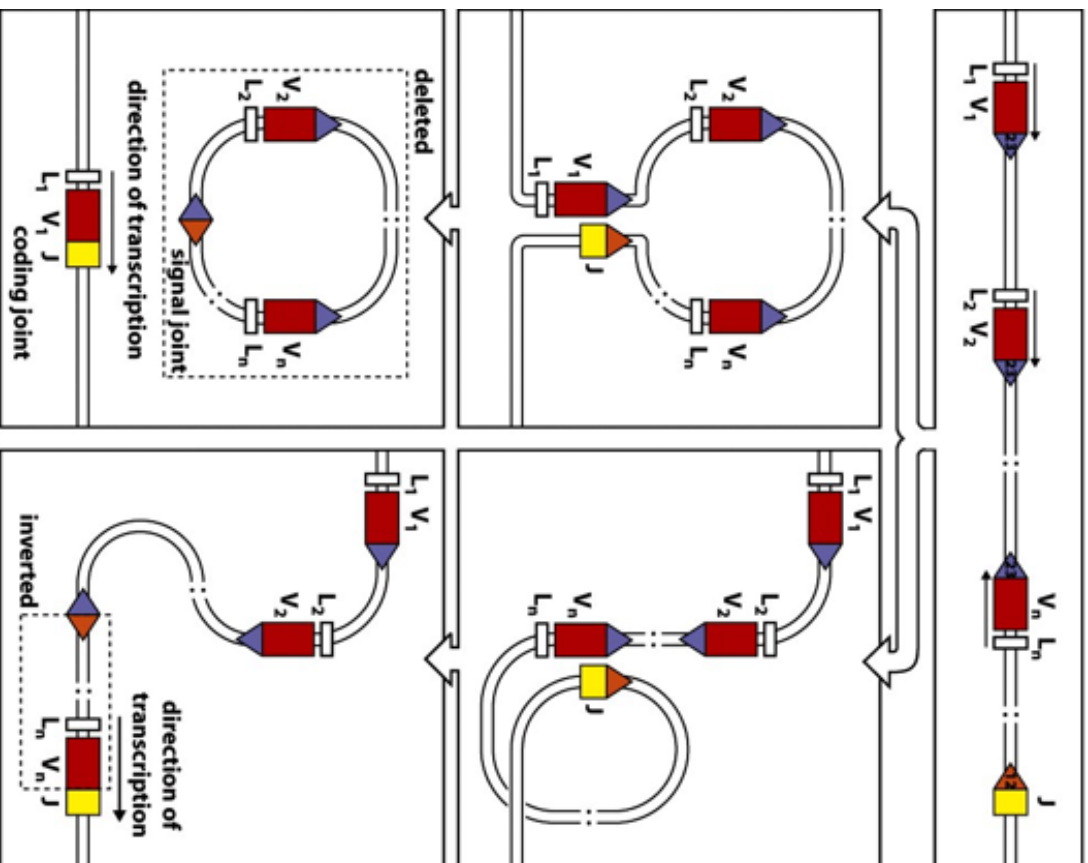

II - Cellules de l'immunité adaptative

Lymphocytes B

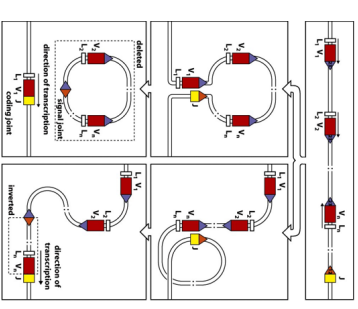
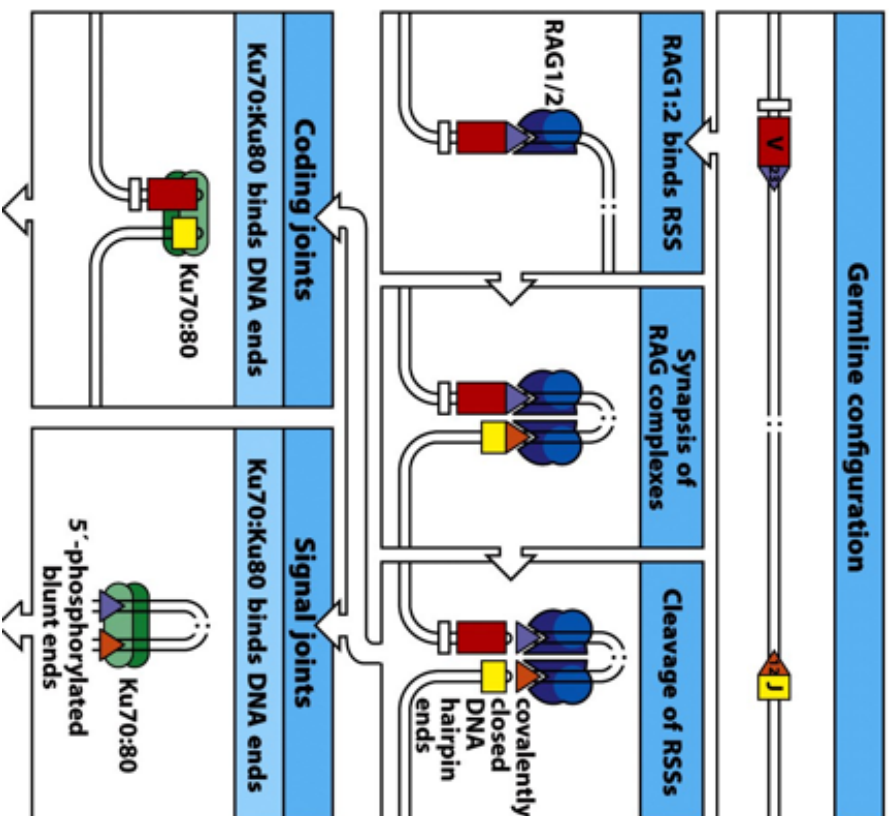

II - Cellules de l'immunité adaptative

Lymphocytes B

Action de la TdT

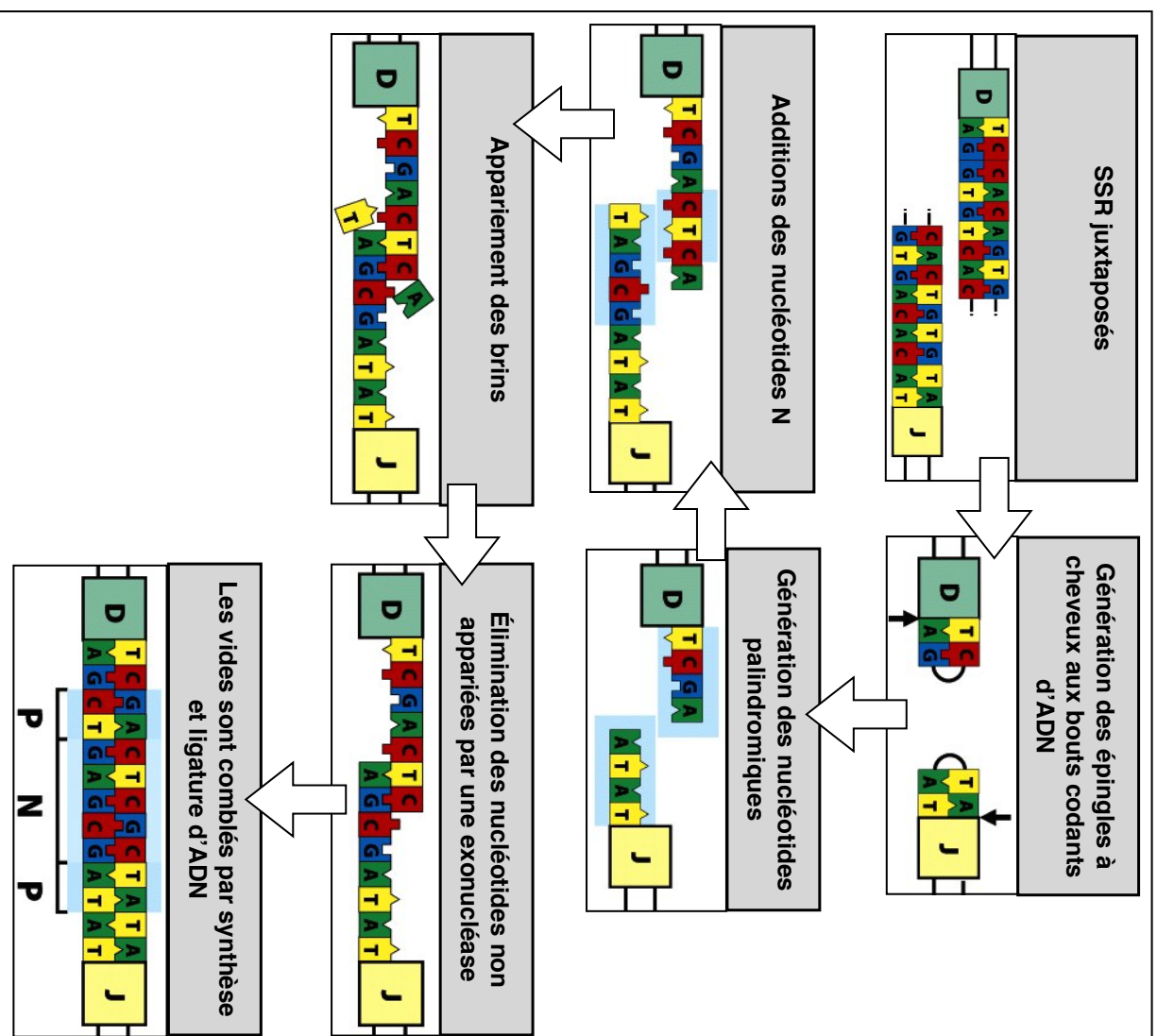

Variabilité jonctionnelle

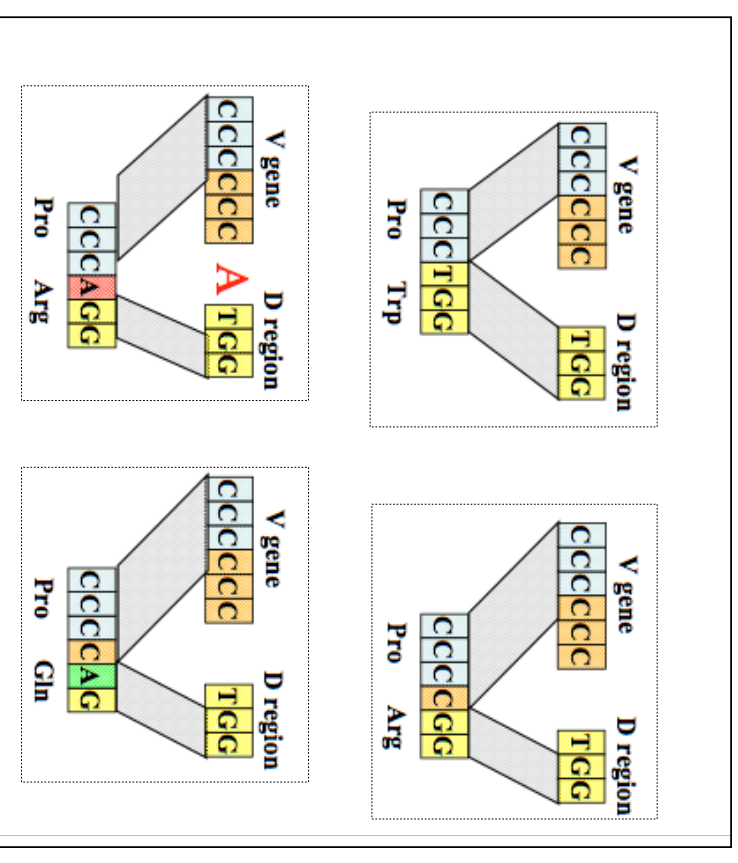

II - Cellules de l'immunité adaptative

Lymphocytes B

Action de la Tdt

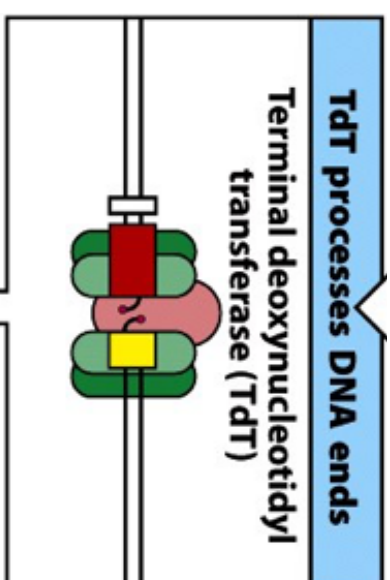
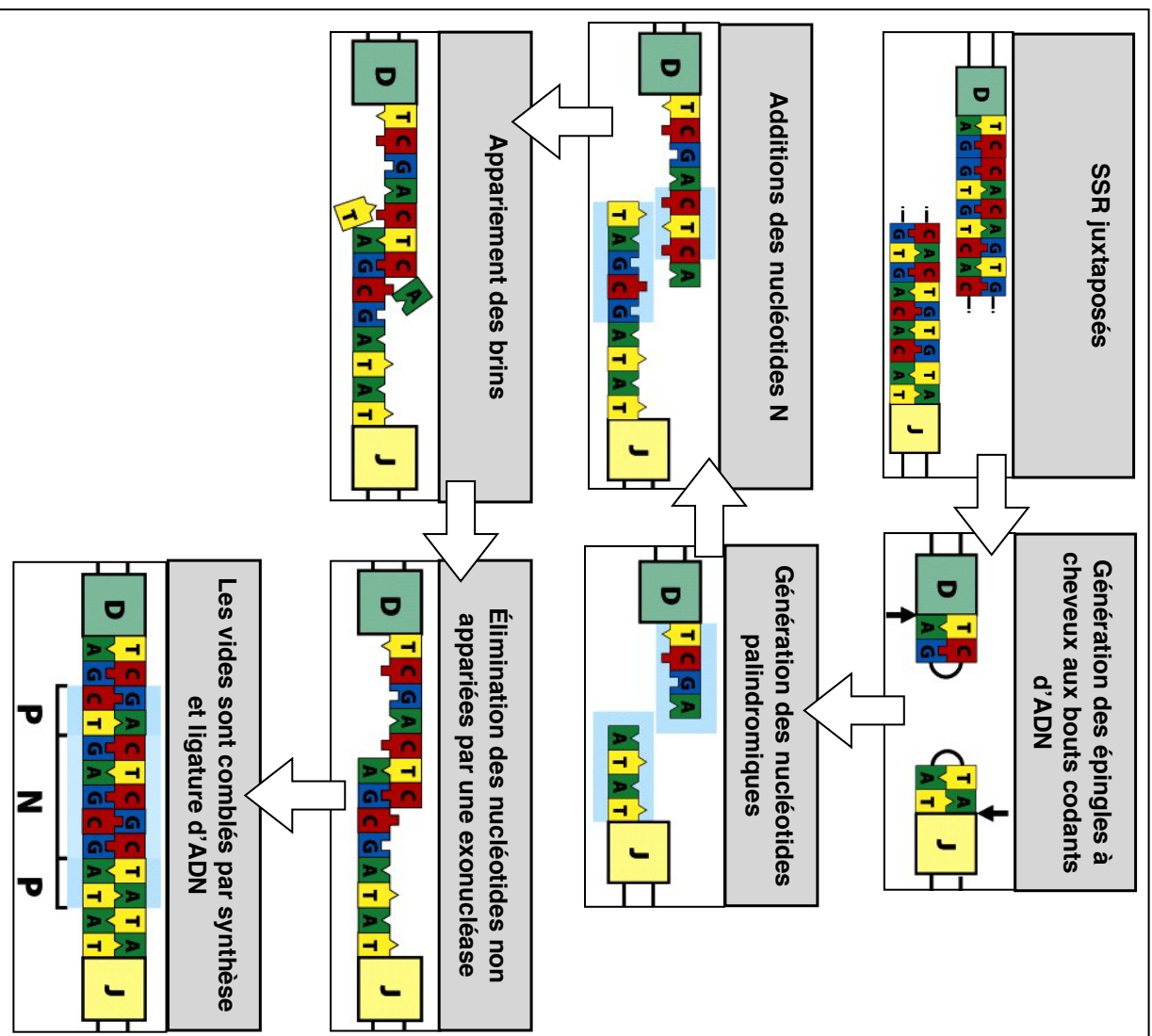

Variabilité jonctionnelle

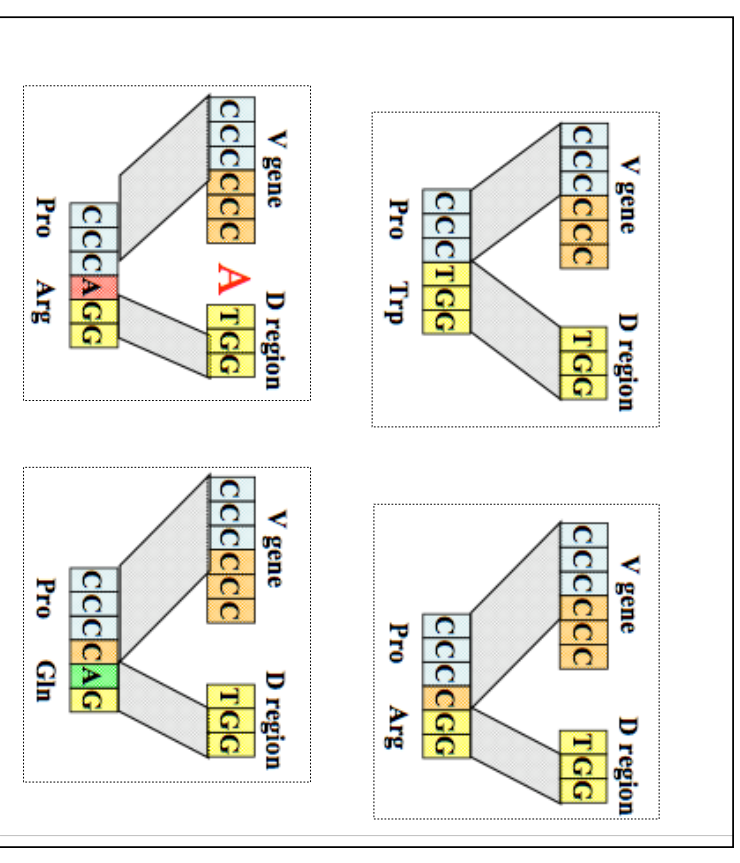

II - Cellules de l'immunité adaptative

Lymphocytes B

Tolérance centrale

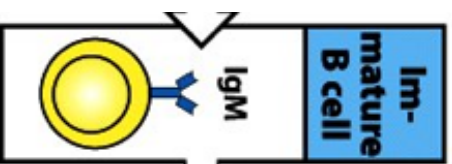
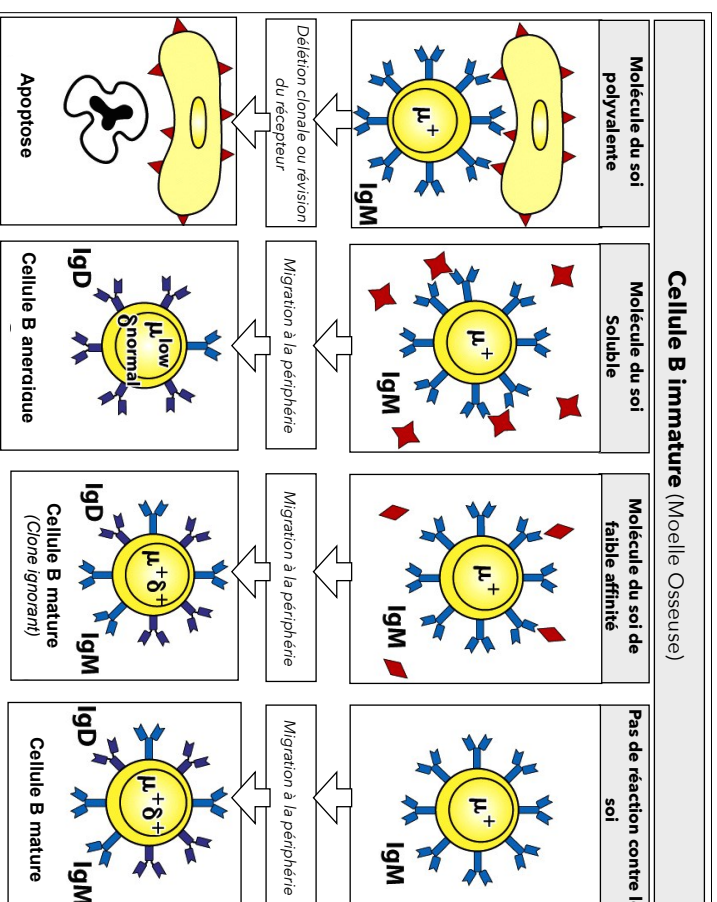

II- Cellules de l'immunité adaptative

Lymphocytes B

Tolérance centrale

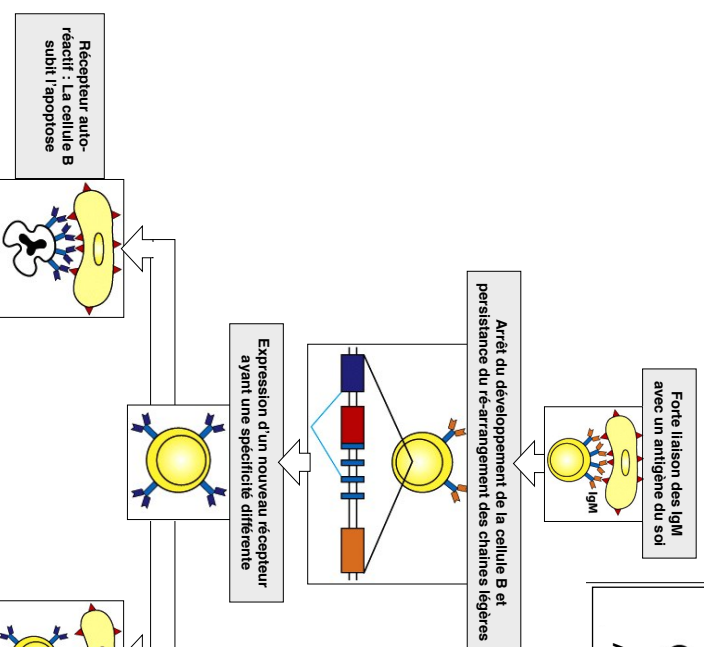
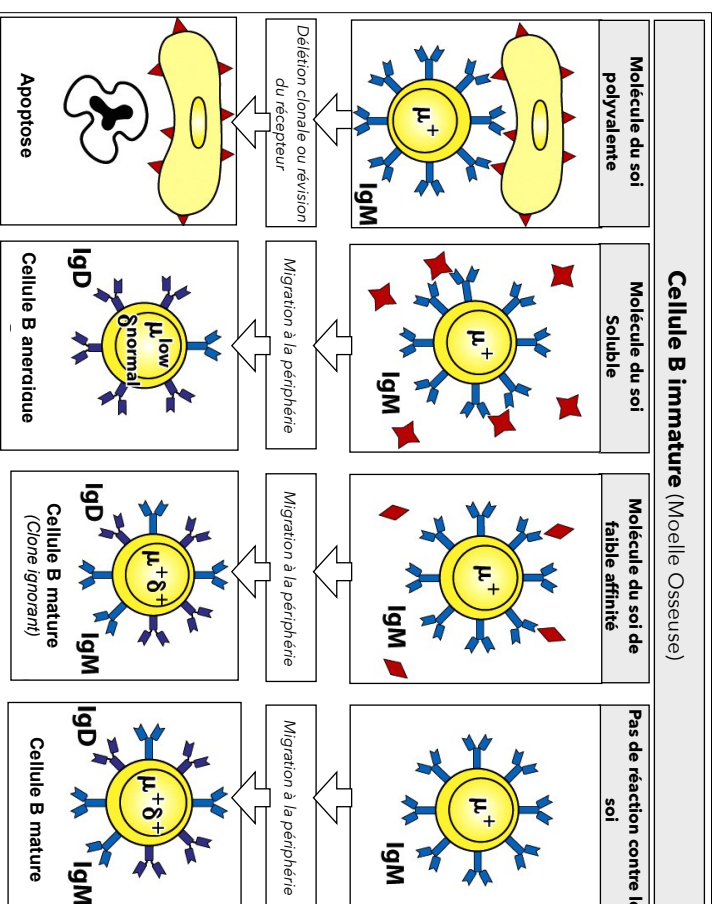
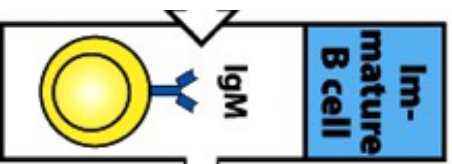

II - Cellules de l'immunité adaptative

Lymphocytes B

Hypermutation somatique

