

# II - Cellules de l'immunité adaptative Lymphocytes B

## Réarrangement des Immunoglobulines

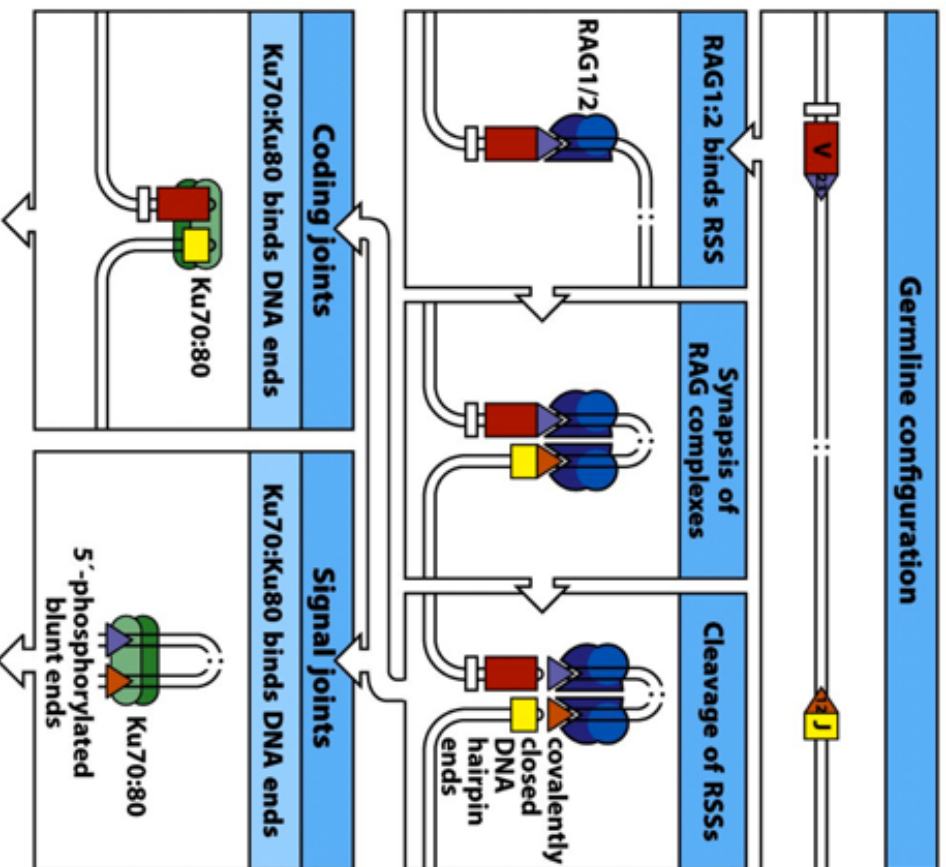

Figure 4-7 part 1 of 2 Immunobiology, 7ed. (© Garland Science 2008)

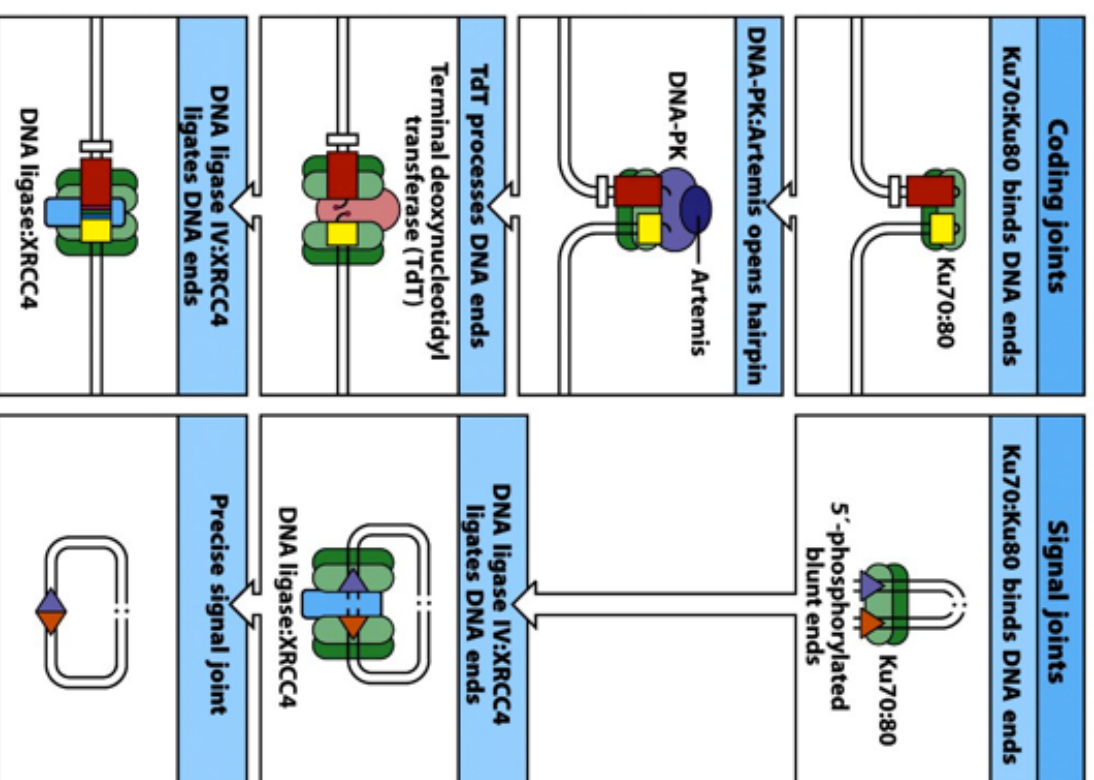

Figure 4-7 part 2 of 2 Immunobiology, 7ed. (© Garland Science 2008)

# II - Cellules de l'immunité adaptative Lymphocytes B

## Réarrangement des Immunoglobulines

- Plusieurs segments de gènes V
- Diversité combinatoire : V<sub>J</sub> et V-D-J
- Diversité jonctionnelle
- **N insertions**
- Acides aminés non codés
- Rôle de la TdT (Terminal Deoxynucleotidyl Transferase)
- **Mutations somatiques**

A

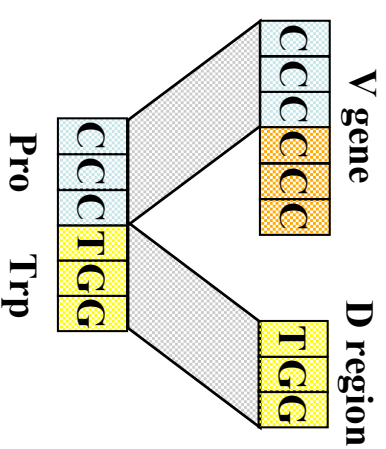

B

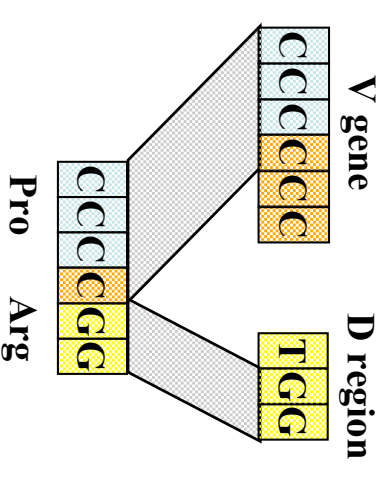

C

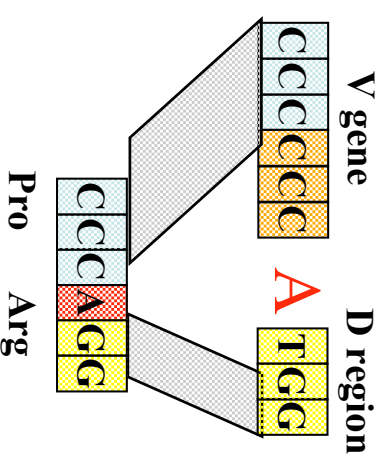

D

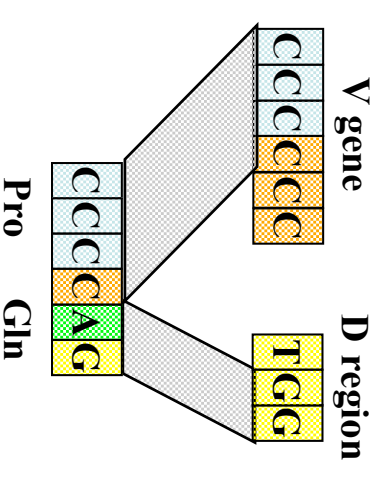

# II - Cellules de l'immunité adaptative Lymphocytes B

## Réarrangement des Immunoglobulines

### Action de la TdT

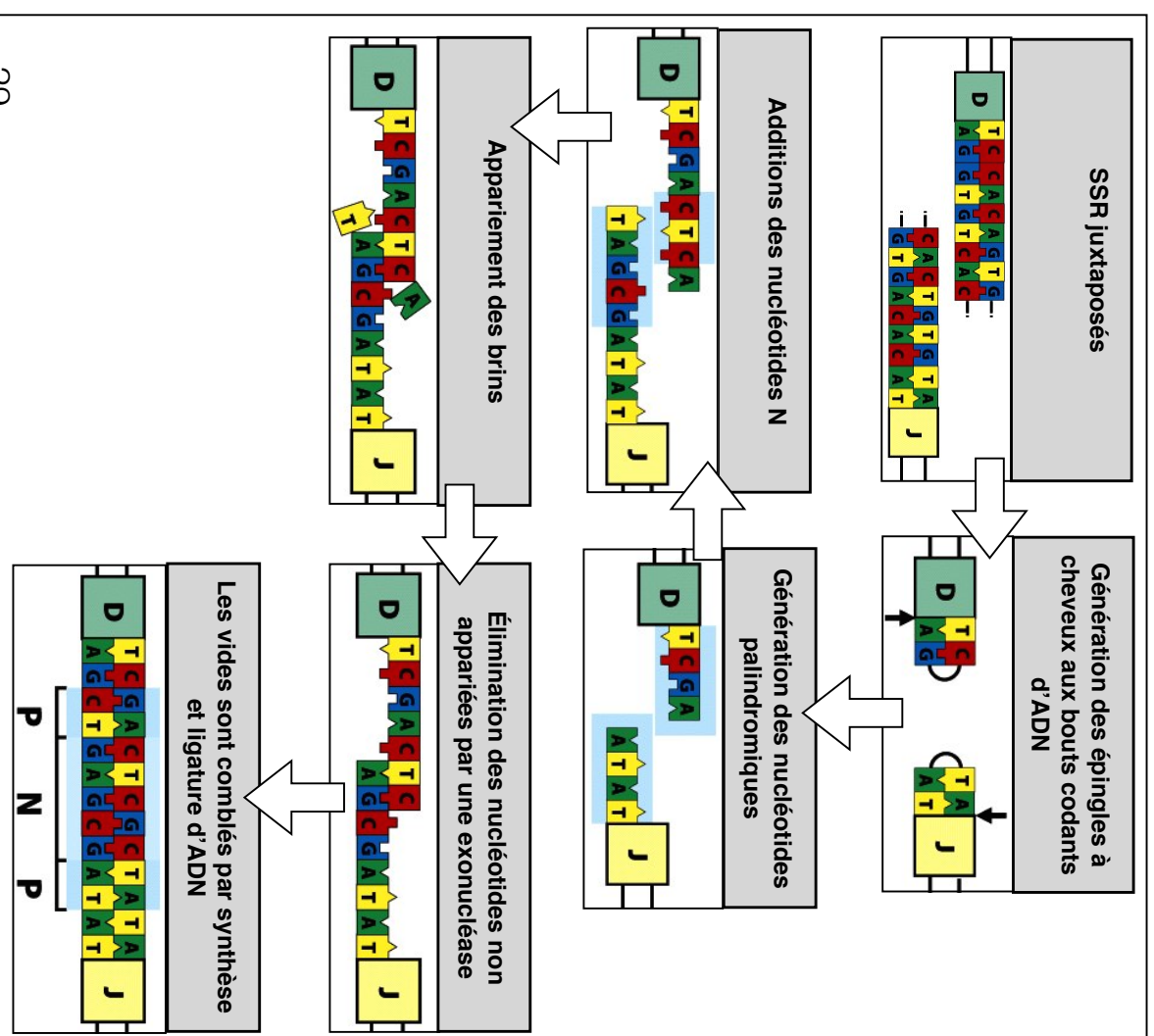
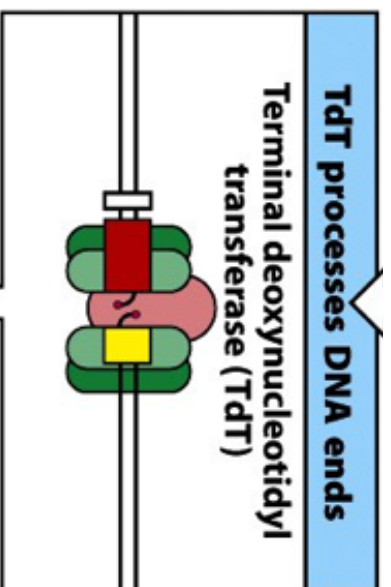

# II - Cellules de l'immunité adaptative Lymphocytes B

## Réarrangement des Immunoglobulines : cas du BCR

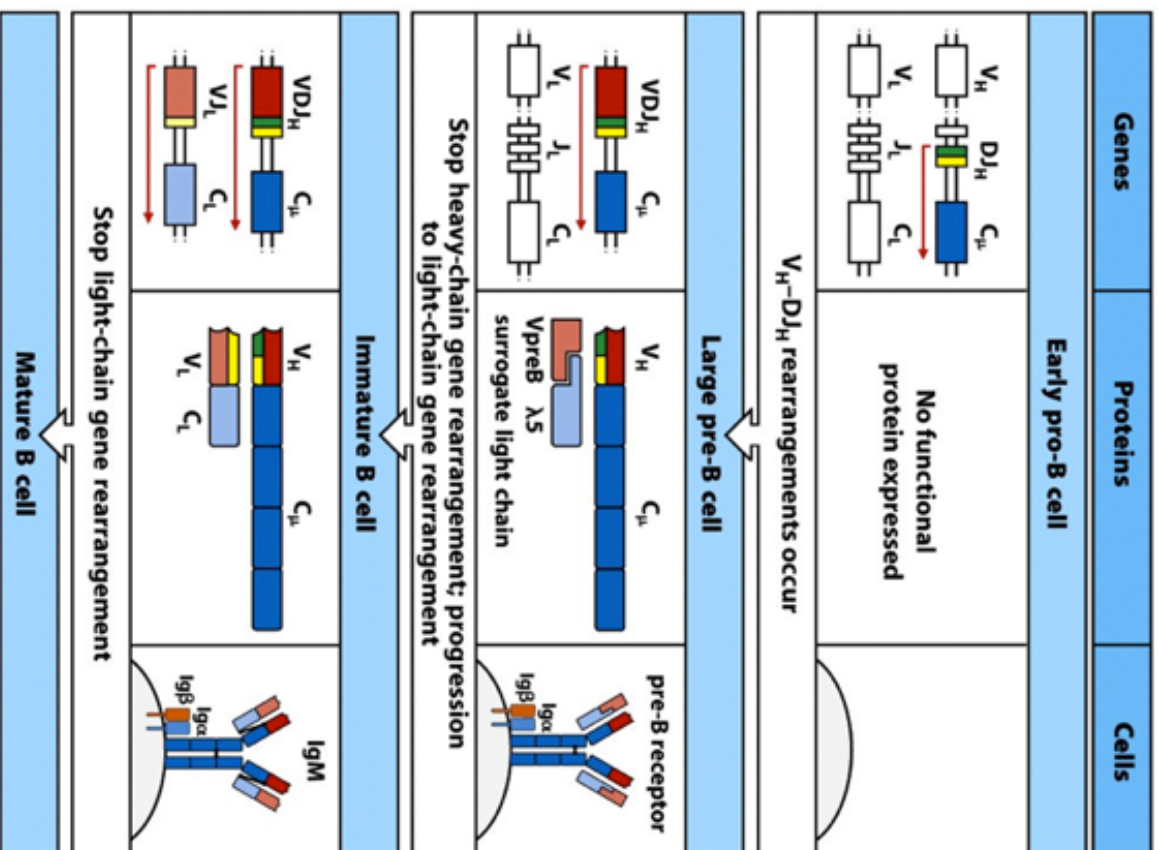
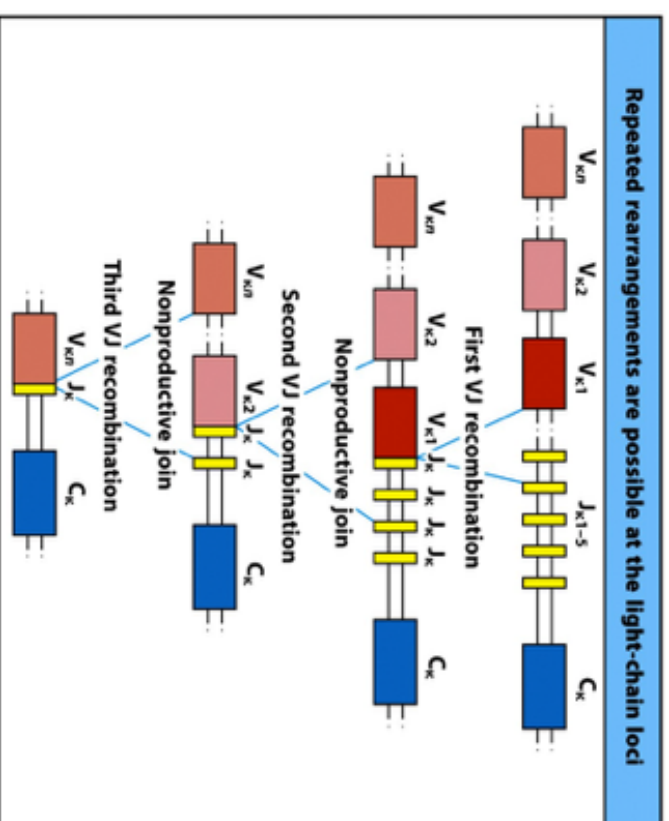

Figure 7-7 Immunobiology, 7ed, © Garland Science 2008)



# II - Cellules de l'immunité adaptative Lymphocytes B

## Réarrangement des Immunoglobulines : cas du BCR

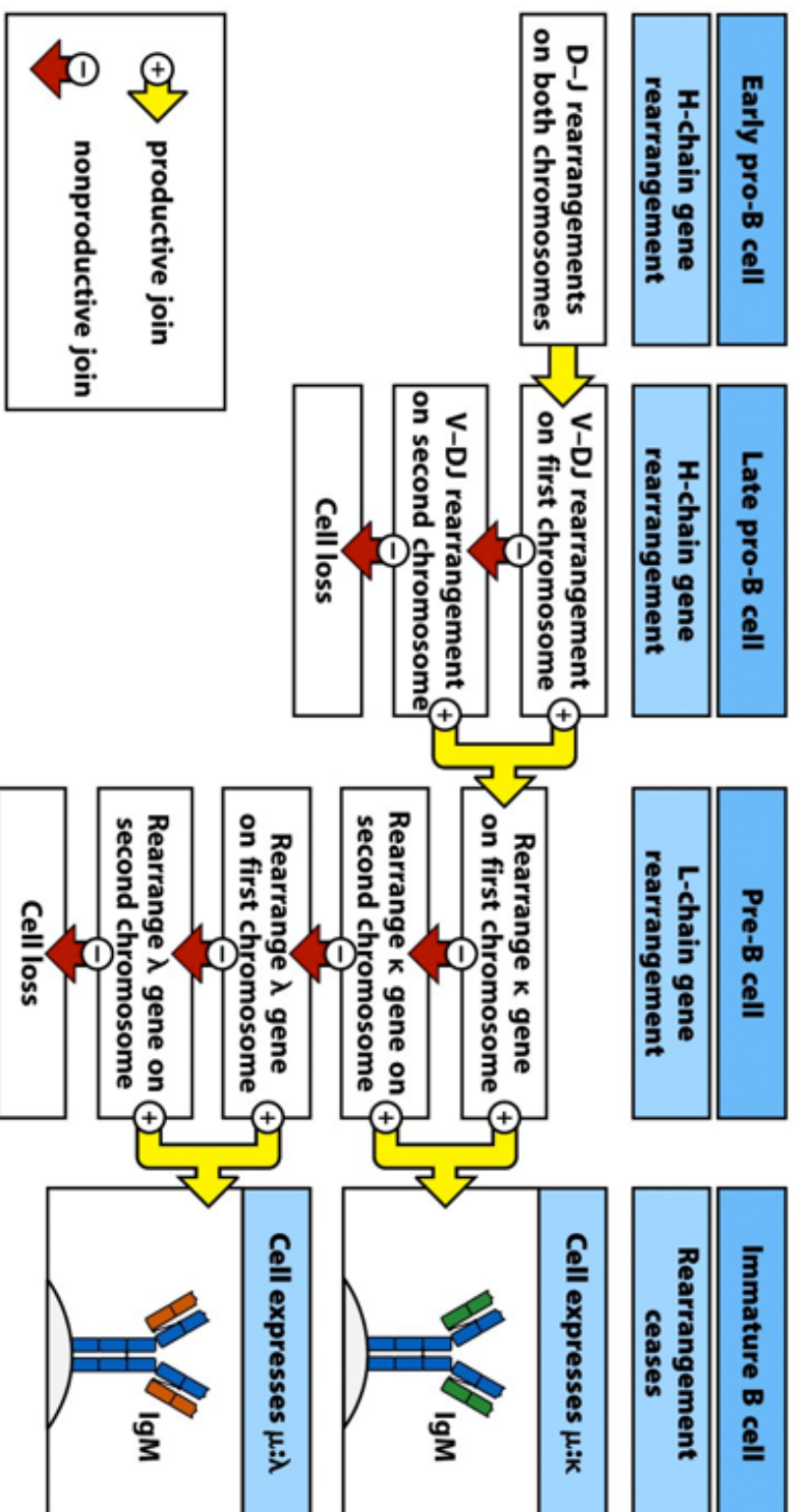

Figure 7-11 Immunobiology, 7 ed. (© Garland Science 2008)

# II - Cellules de l'immunité adaptative

## Lymphocytes B

### Expression d'IgM & IgD

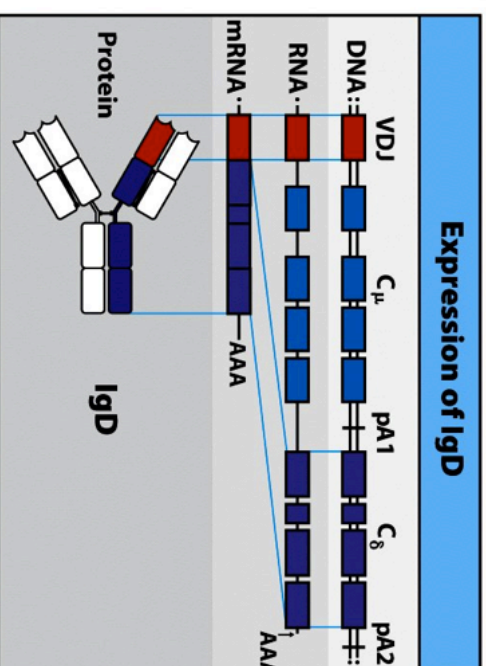
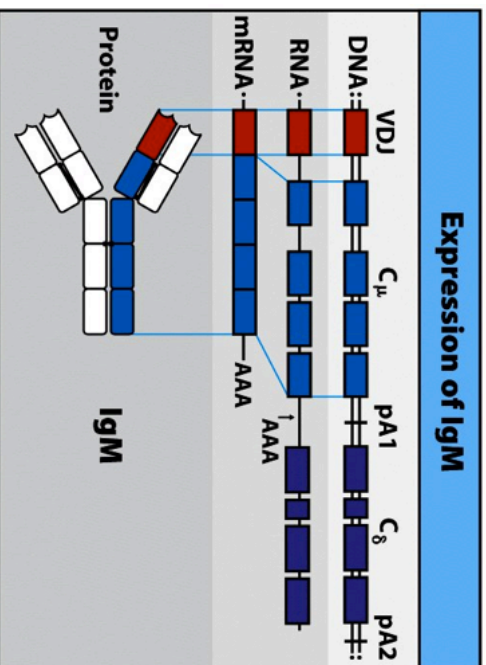
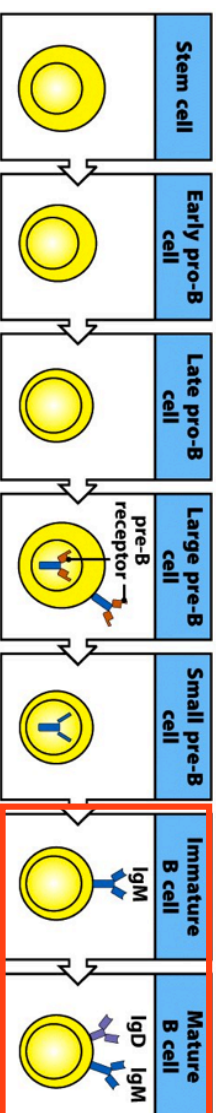

Figure 4-18 Immunobiology, 7ed, (© Garland Science 2008)

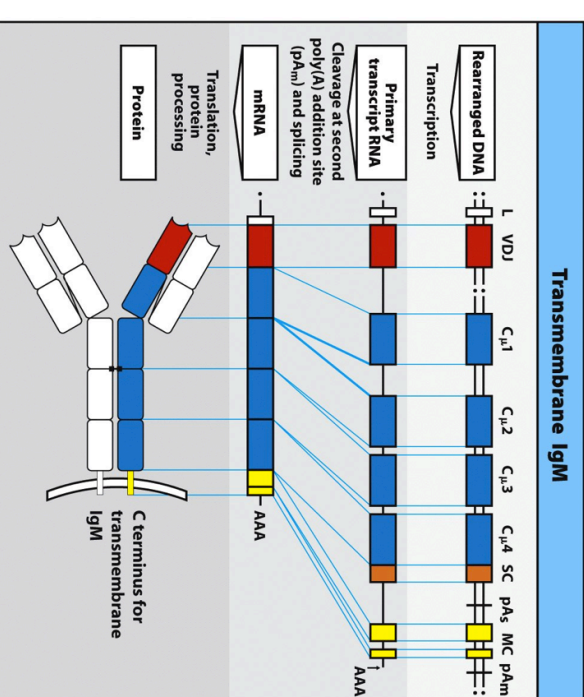
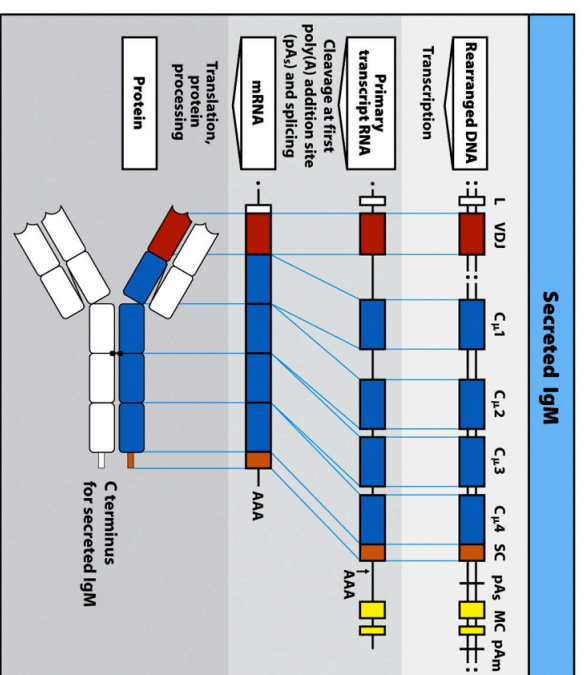

Figure 4-19 part 2 of 2 Immunobiology, 7ed, (© Garland Science 2008)

Figure 4-19 part 1 of 2 Immunobiology, 7ed, (© Garland Science 2008)

# II - Cellules de l'immunité adaptative Lymphocytes B

Comment est il possible qu'un antigène soit reconnu par de nombreux anticorps avec des affinités différentes ?

Les mutations somatiques

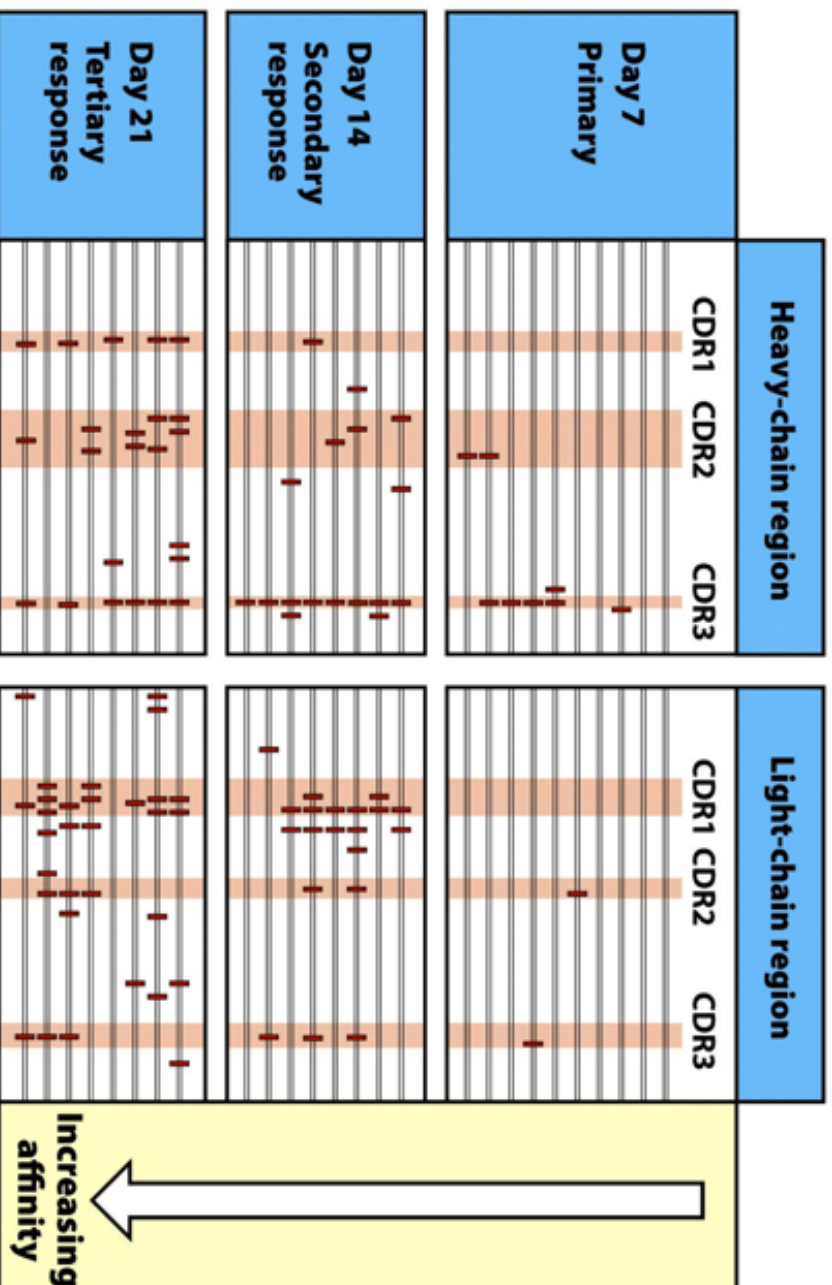

Figure 4-25 Immunobiology, 7ed, (© Garland Science 2008)

# II - Cellules de l'immunité adaptative Lymphocytes B

## Les mutations somatiques

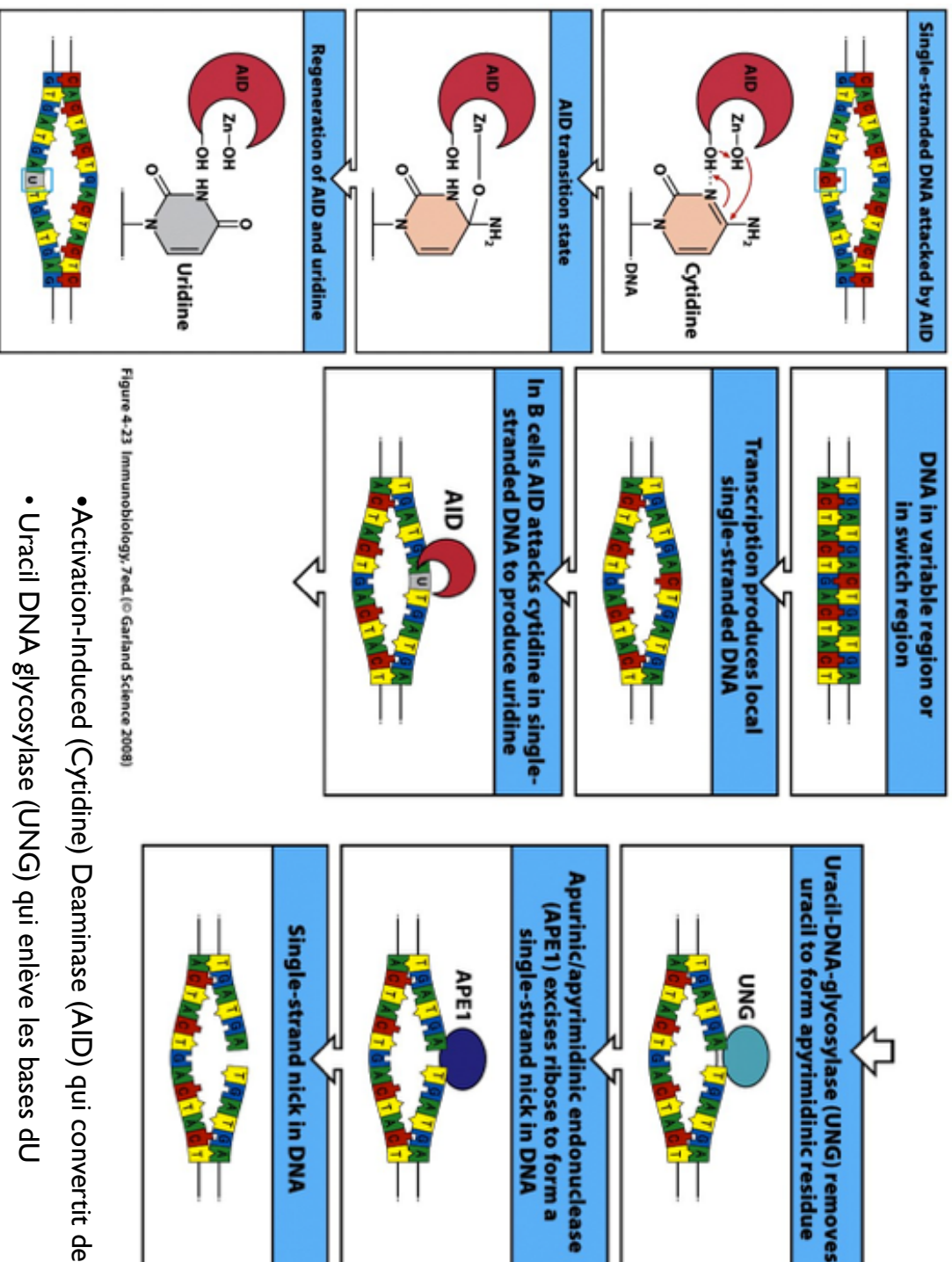

Figure 4-23 Immunobiology, 7ed. (© Garland Science 2008)

Figure 4-22 Immunobiology, 7ed. (© Garland Science 2008)

- Activation-Induced (Cytidine) Deaminase (AID) qui convertit des cytosines en Uracils au niveau des séquences S
- Uracil DNA glycosylase (UNG) qui enlève les bases dU
- Apurinic/apyrimidinic endonuclease (APE) qui répare les sites sans bases.

# II - Cellules de l'immunité adaptative Lymphocytes B

Comment Les LB passent de la production des IgM aux IgG ?

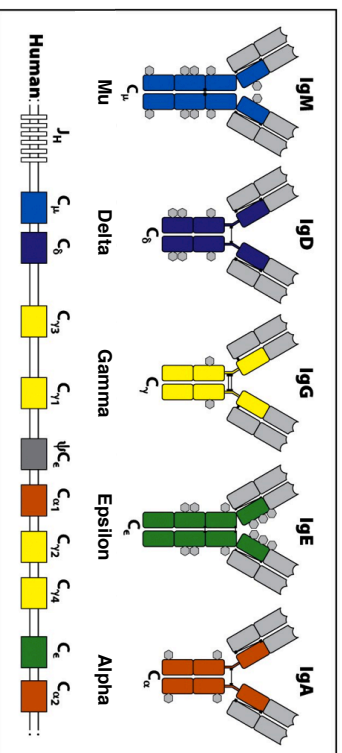

Commutation de classe

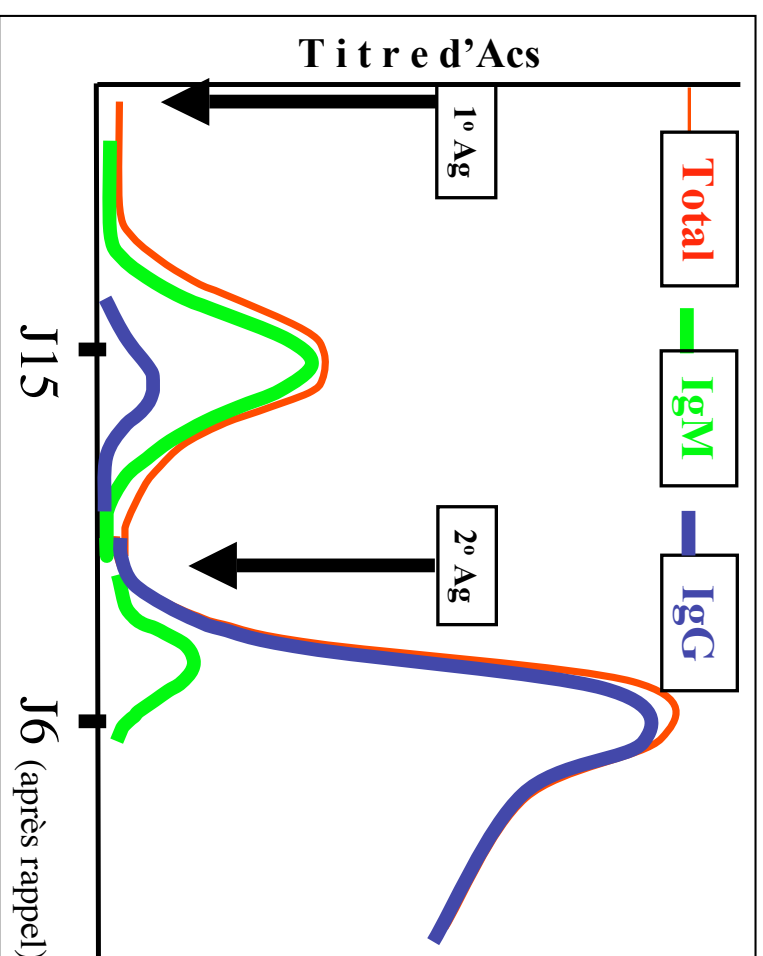

# II - Cellules de l'immunité adaptative Lymphocytes B

Interaction CD40/CD40L

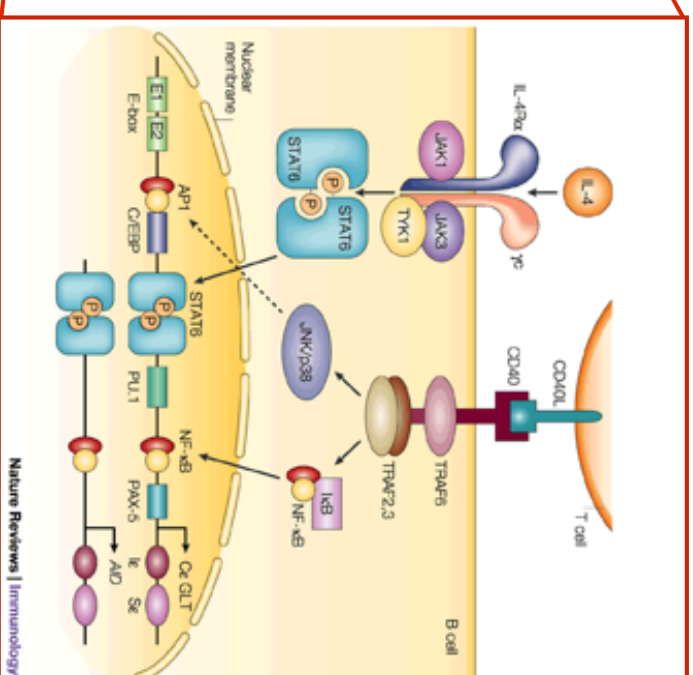
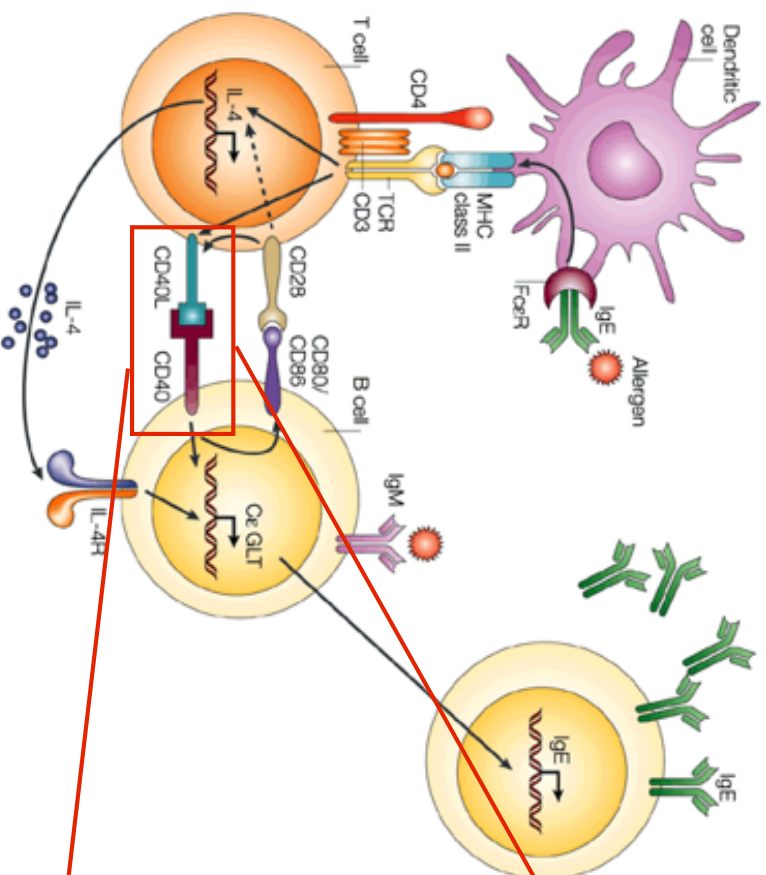

Nature Reviews | Immunology

# II - Cellules de l'immunité adaptative Lymphocytes B

## Commutation de classe « Switch »

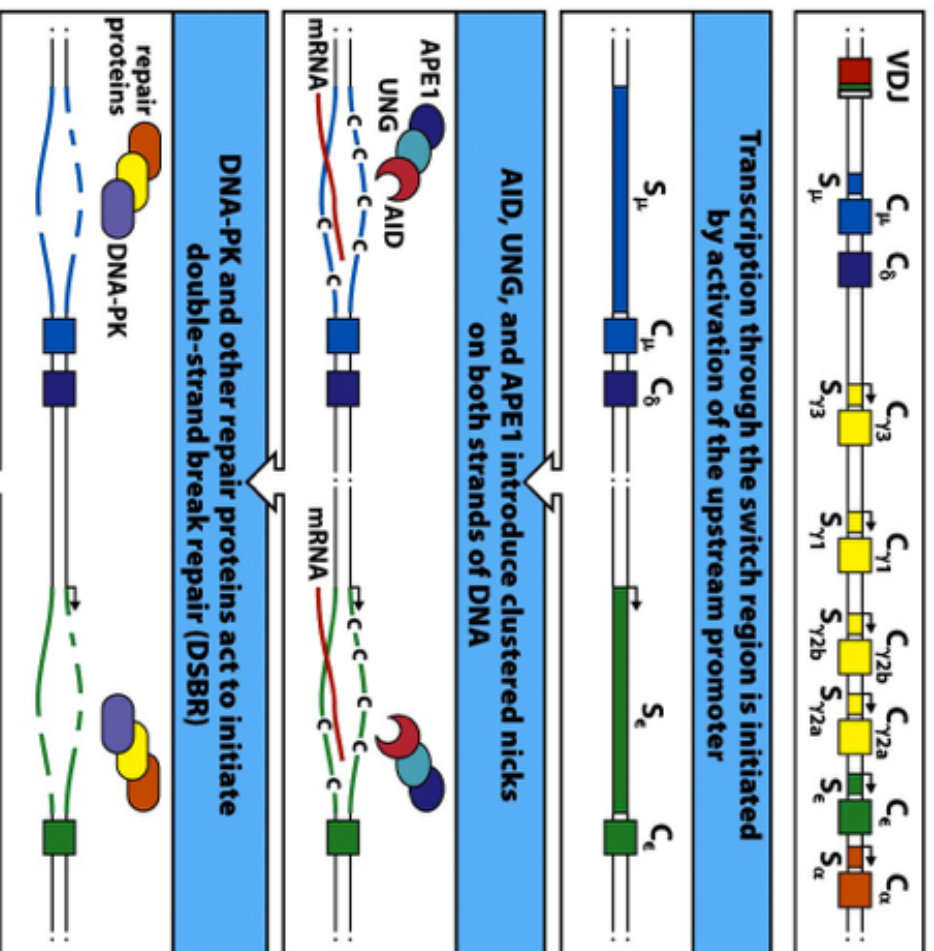

Figure 4-27 part 1 of 2 Immunobiology, 7ed. (© Garland Science 2008)

*Le switch produit une protéine fonctionnelle*

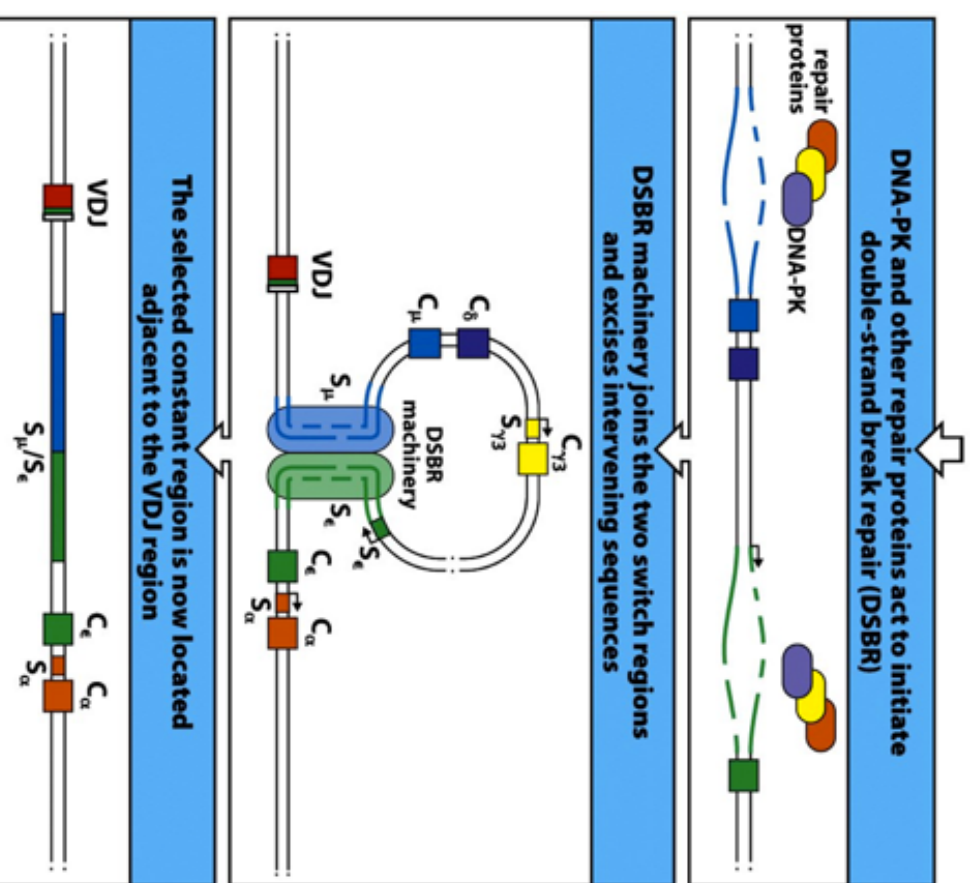
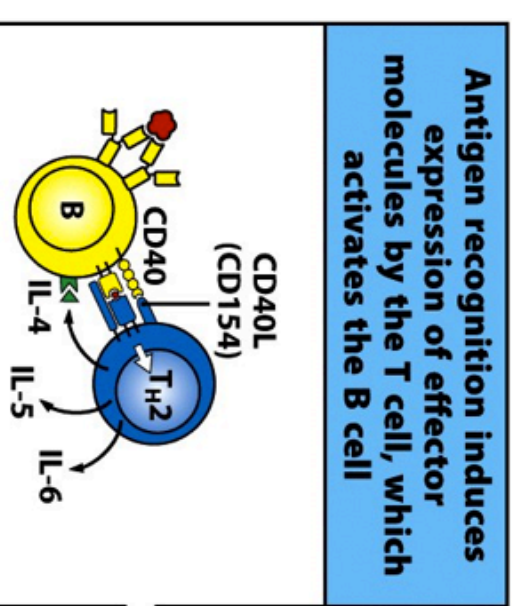

Figure 4-27 part 2 of 2 Immunobiology, 7ed. (© Garland Science 2008)

# II - Cellules de l'immunité adaptative Lymphocytes B

Commutation de classe « Switch »



ed. (© Garland Science 2008)

## Role of cytokines in regulating expression of antibody classes

Cytokines	IgM	IgG3	IgG1	IgG2b	IgG2a	IgE	IgA
IL-4	Inhibits	Inhibits	Induces		Inhibits	Induces	
IL-5							Augments production
IFN- $\gamma$	Inhibits	Induces	Inhibits		Induces	Inhibits	
TGF- $\beta$	Inhibits	Inhibits		Induces			Induces

Figure 9-13 Immunobiology, 7ed. (© Garland Science 2008)

# II- Cellules de l'immunité adaptative Lymphocytes B

## Tolérance centrale

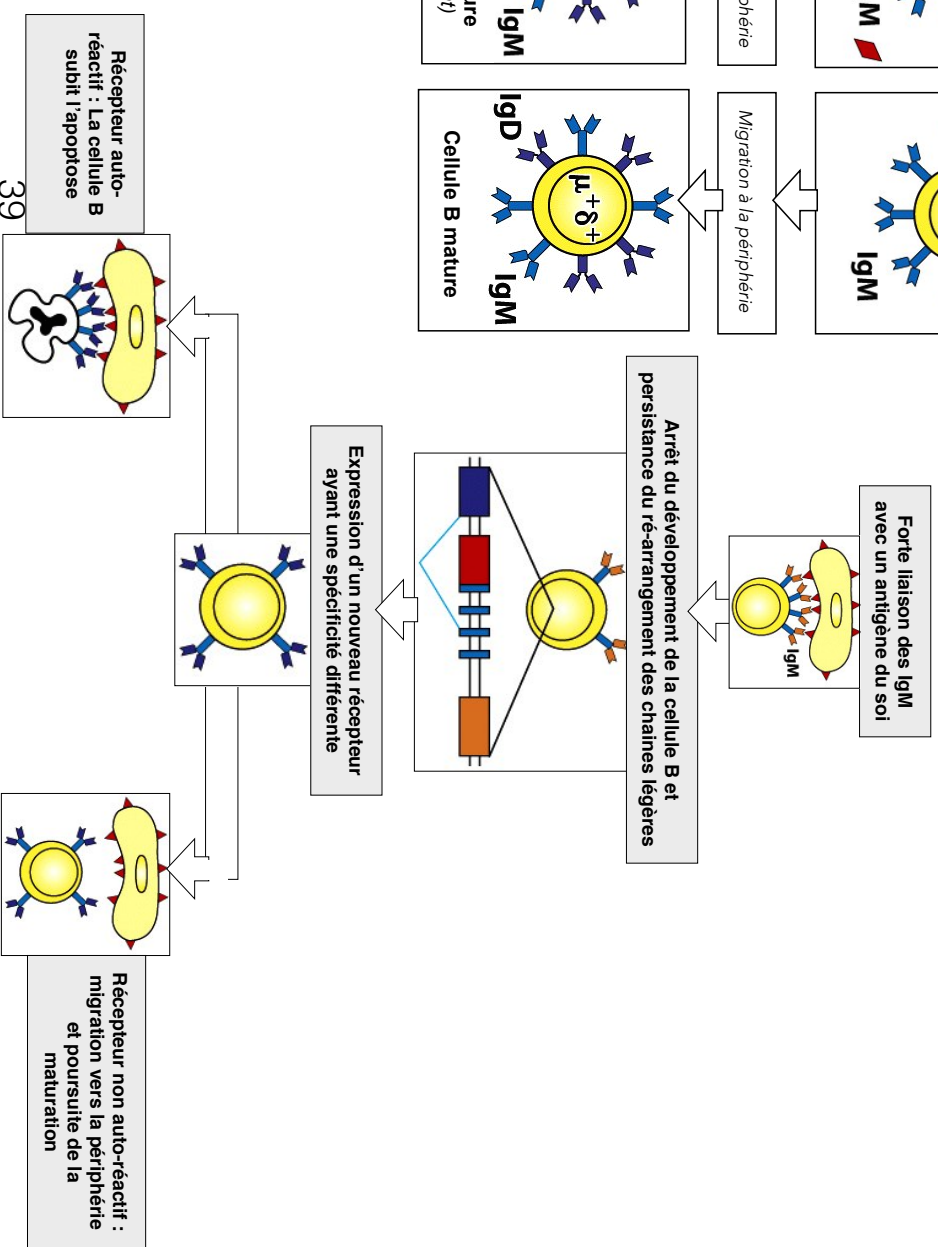
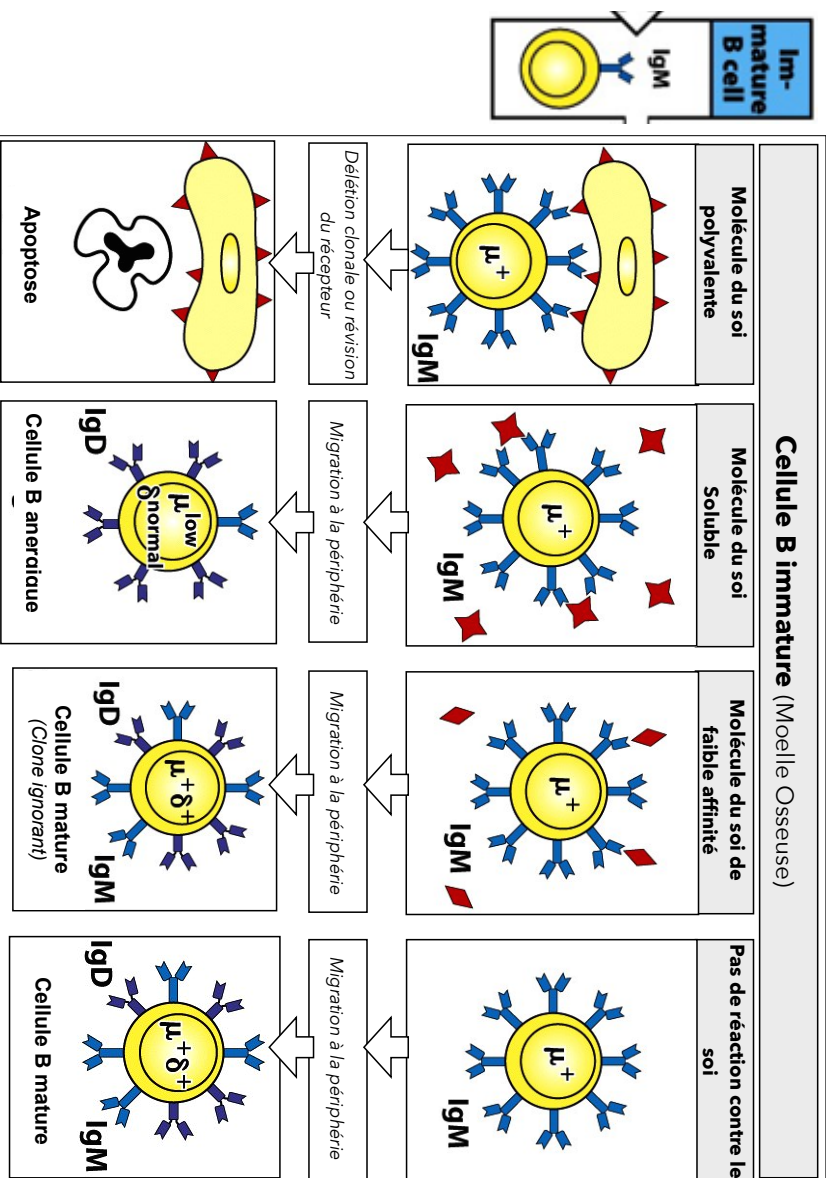

# II - Cellules de l'immunité adaptative Lymphocytes B

## Mécanismes de reconnaissance & d'action

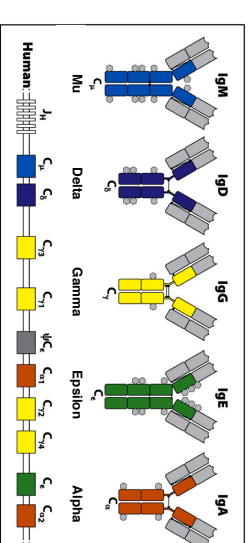
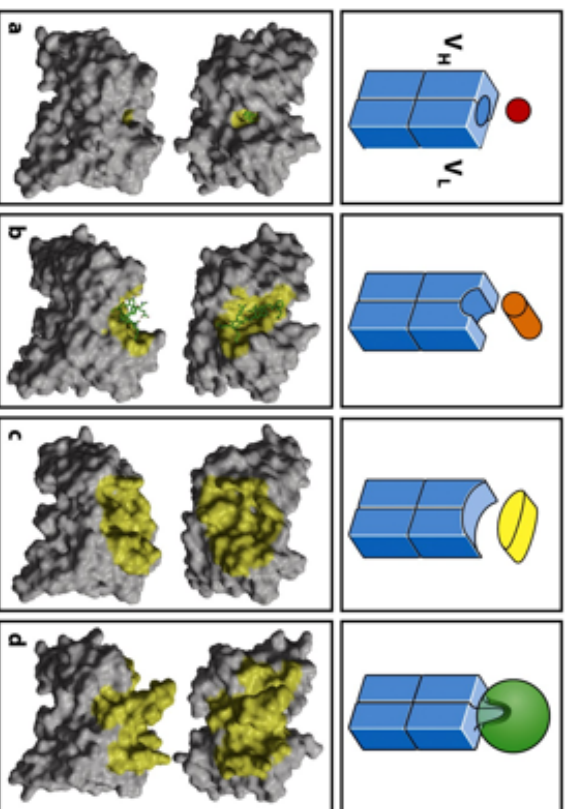
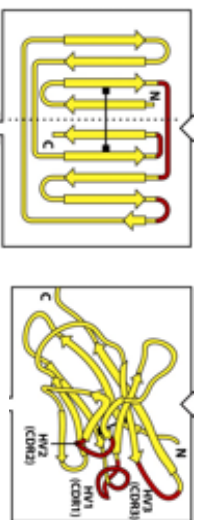
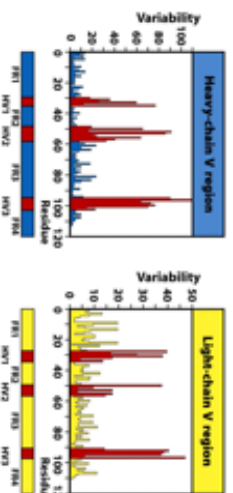

Functional activity	IgM	IgD	IgG1	IgG2	IgG3	IgG4	IgA	IgE
Neutralization	+	-	++	++	++	++	++	-
Opsonization	+	-	+++	*	++	+	+	-
Sensitization for killing by NK cells	-	-	++	-	++	-	-	-
Sensitization of mast cells	-	-	+	-	+	-	-	+++
Activates complement system	+++	-	++	+	+++	-	+	-

Distribution	IgM	IgD	IgG1	IgG2	IgG3	IgG4	IgA	IgE
Transport across epithelium	+	-	-	-	-	-	+++ (dimer)	-
Transport across placenta	-	-	+++	+	++	+/-	-	-
Diffusion into extravascular sites	+/-	-	+++	+++	+++	+++	++ (monomer)	+
Mean serum level (mg ml <sup>-1</sup> )	1.5	0.04	9	3	1	0.5	2.1	3 × 10 <sup>-5</sup>

# II- Cellules de l'immunité adaptative

## Lymphocytes B

*Quand le processus de maturation est imparfait : Déficiets Immunitaires innée*

### Agammaglobulinémie liée à l'X

- Maladie de Bruton, 1<sup>ere</sup> PID décrite
- Trouble Immunitaire rare (1/200000)
- Plus d'hommes que de femmes, lié aux Chrs X
- Caractérisé par des maladies infectieuses à répétition
- Arrêt de la maturation au stade pre-B
- le gène responsable est la *Btk*

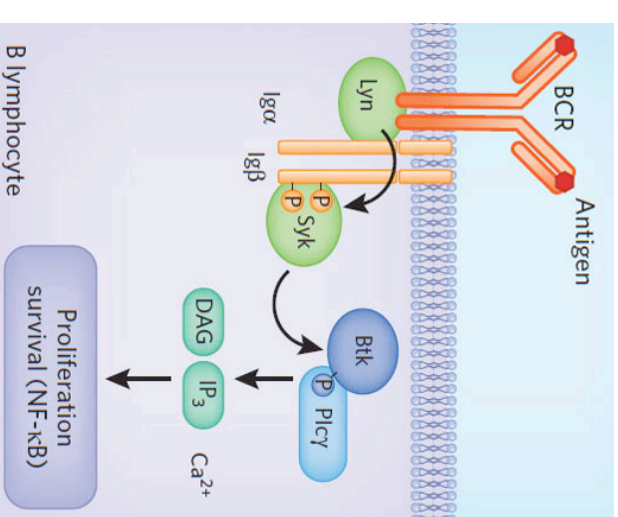
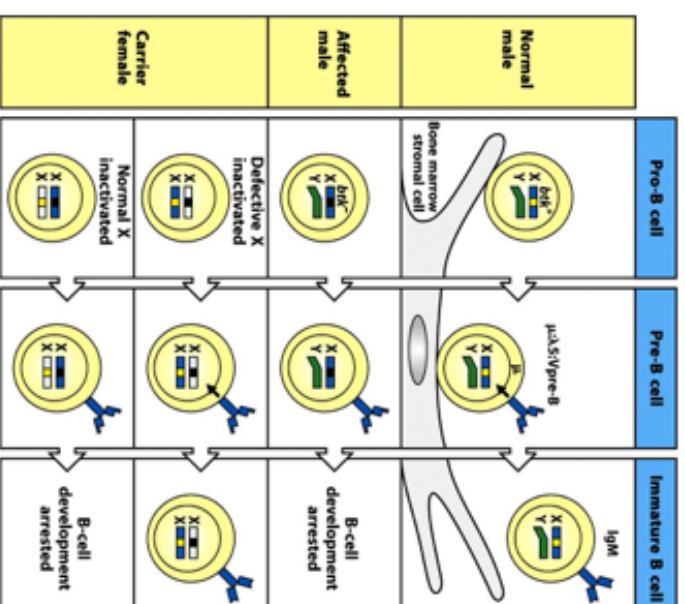
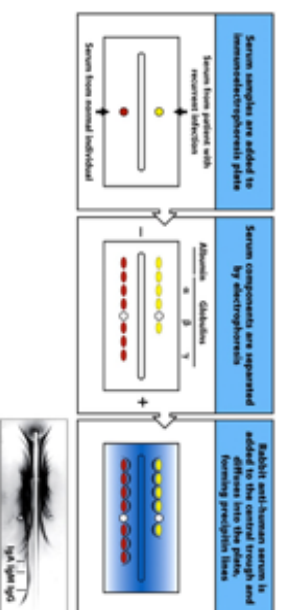

# II - Cellules de l'immunité adaptative

## Lymphocytes B

*Quand le processus de maturation est imparfait : Déficits Immunitaires innée*

### Immunodéficience hyper IgM

- Entité hétérogène
- Pouvant se présenter à tout âge
- Infections récurrentes & Réponses vaccinales incomplètes
- Présence de Lymphocyte B, – et une immunité T normale ou quasi normale.

★ Dysplasie ectodermique hypohidrotique avec immunodéficience : absence de la protéine NEMO

★ Syndrome Hyper IgM lié au Chrs X (CD40L) : association avec une anomalie de l'expansion des LT antigène spécifiques

★ Déficience de AID : moins sévère

# II - Cellules de l'immunité adaptative

## Lymphocytes B

*Quand le processus de maturation est imparfait : Déficiets Immunitaires innée*

**Immunodéficience hyper IgM**

